



FAD:™ FAN AIR DISPOSAL VAPORIZERS

Thermax FAD,™ Fan-Air Ambient Disposal Vaporizers are designed to accept low pressure oxygen, nitrogen, argon liquid, mix and vaporize the cryogen and exhaust the cool mixture vertically into the atmosphere.

Generally, disposal of "off-spec." cryogens is routinely required in cryogenic plants.

Features

- Thermax Disposal Injector system, usually of copper
- High performance direct or belt drive fan assembly
- Totally enclosed TEFC or TEAO motor
- Heavy duty structural aluminum framing
- Motor starter with optional disconnect, NEMA 3R
- Auto-start temperature control
- Low temperature signal
- Heavy gauge aluminum duct/mix chamber

Performance

FAD™ Disposal Vaporizers consist of a Thermax designed cryogen injector system housed in a vertical air duct. An updraft fan forces air over the injectors, rapidly vaporizing the cryogen jets and mixing the combined air-cryogen prior to exhaust to the surrounding atmosphere. Design performance is based on either a final fixed exhaust temperature in the -100°F range, or an exhaust temperature based on the difference between air temperature and exhaust mix temperature (approach temperature), usually in the 50 to 75°F range. The smaller the approach temp; the lower the probability of a nuisance fog plume.

CAUTIONS: Venting oxygen into the atmosphere causes O₂ enrichment. Also, a cold plume occurs above the vaporizer causing a fog plume with the surrounding air. The plant designer must consider these factors in his site plan.

Thermax also offers Cold Water (Datasheet 7.0) and Steam (Datasheet 5.0) Heated Disposal Vaporizers.



Thermax FAD 250 on 55,000 lb/HR O₂N₂ capacity at exit temp 50° below air temp using 30 hp fan



Actual Thermax injector test with liquid nitrogen

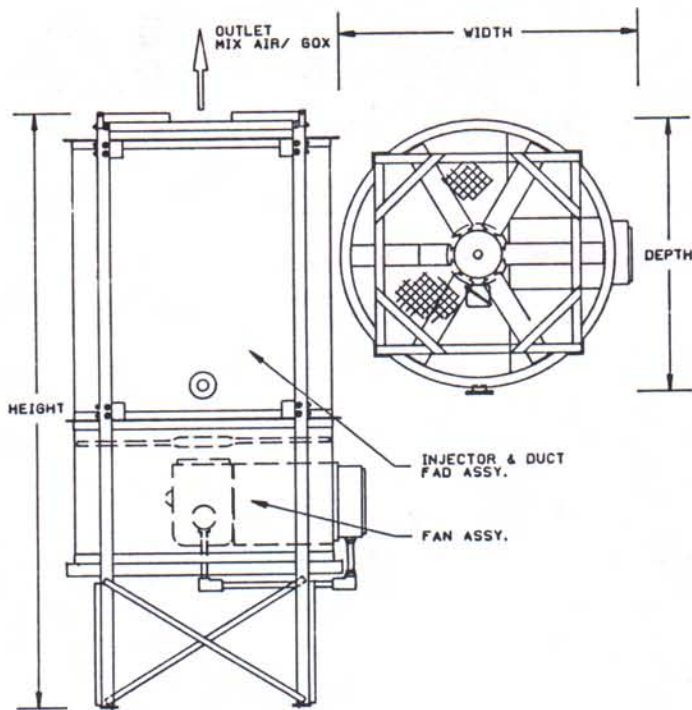

TYPICAL ARRANGEMENT
(SOME UNITS MAY BE SQUARE IN PLAN VIEW)

OVERALL DIMENSIONS and WEIGHTS*						
MODEL	HP	CON. NPT	WIDTH	DEPTH	HEIGHT INCHES	WEIGHT LBS.
FAD 10	1	2	30	30	94	500
FAD 20	2	2	36	36	94	700
FAD 30	3	2	42	40	100	900
FAD 40	5	2 1/2	49	44	106	1,000
FAD 50	5	2 1/2	55	48	102	1,200
FAD 60	7 1/2	3	56	52	112	1,400
FAD 80	7 1/2	3	64	54	122	1,500
FAD 90	10	3 1/2	72	58	130	1,700
FAD 100	10	3 1/2	76	60	130	1,800
FAD 120	15	4	84	62	140	2,000
FAD 250	30	4	94	62	200	3,500

* APPROX DATA FOR PLANNING

OPERATING NOTES:

Site plan should include liquid stop valve operated by AUX. T.C. in air near fan motor. Unit normally is designed to operate for 8-48 hours between defrost of ice which collects on injector pipes.

Standard Model Ratings FAD™ series*

MODEL	OXYGEN/NITROGEN/ARGON-LBS/HR	
	*AIR TEMP	EFFLUENT MIX TEMP 50°F
FAD10	2,000	LBS/HR
FAD20	4,000	
FAD30	6,000	
FAD40	8,000	
FAD50	10,000	
FAD60	12,000	
FAD80	16,000	
FAD90	18,000	
FAD100	20,000	
FAD120	24,000	
FAD250	50,000	

*Mix air/gas outlet at 50°F below air temp CRYOGEN Pressure at inet 15 to 30 PSIG (NOM)

STANDARD WIRING DIAGRAM

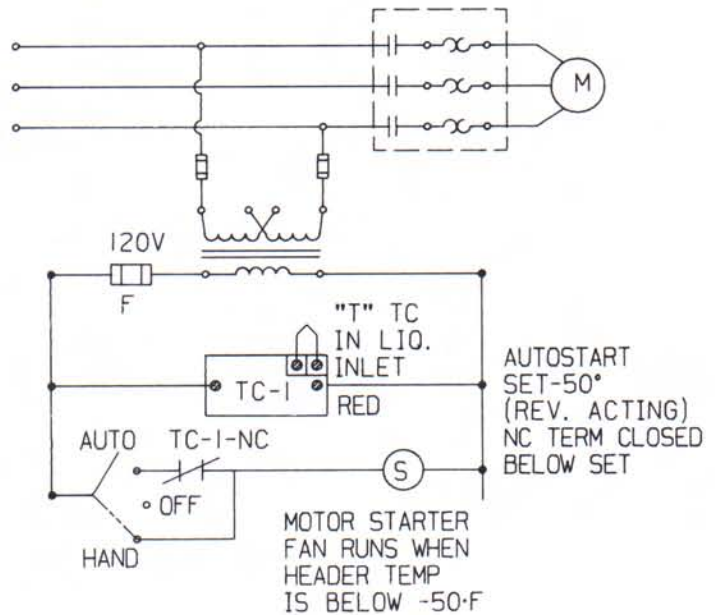

OTHER THERMAX VAPORIZERS AND CRYOGENIC EQUIPMENT

Our 35 page catalog describes our full line of cryogenic vaporizers, related cryogenic heat exchangers and gas heaters, including plant pressure build/purge gas vaporizers; cryogen to gas, cryogen to cryogen exchangers and subcoolers.

All the tables shown here are intended as guides reflecting our experience on these models. Actual performance may vary. This product and/or data was designed and/or developed by Thermax Inc. and shall not be used in any way injurious to the interests of Thermax Inc.

CRYODUCT™ and FAD™ are Thermax Trademarks